

# **X5** (Split Type) **Solar Street Light** Specification 2021

CE | CB | IP66 | IK08



Monocrystalline  
Solar Panel



High Efficiency  
Controller



Battery Management  
System



Superbright  
LED lamps



Motion Sensor



IP66 Waterproof

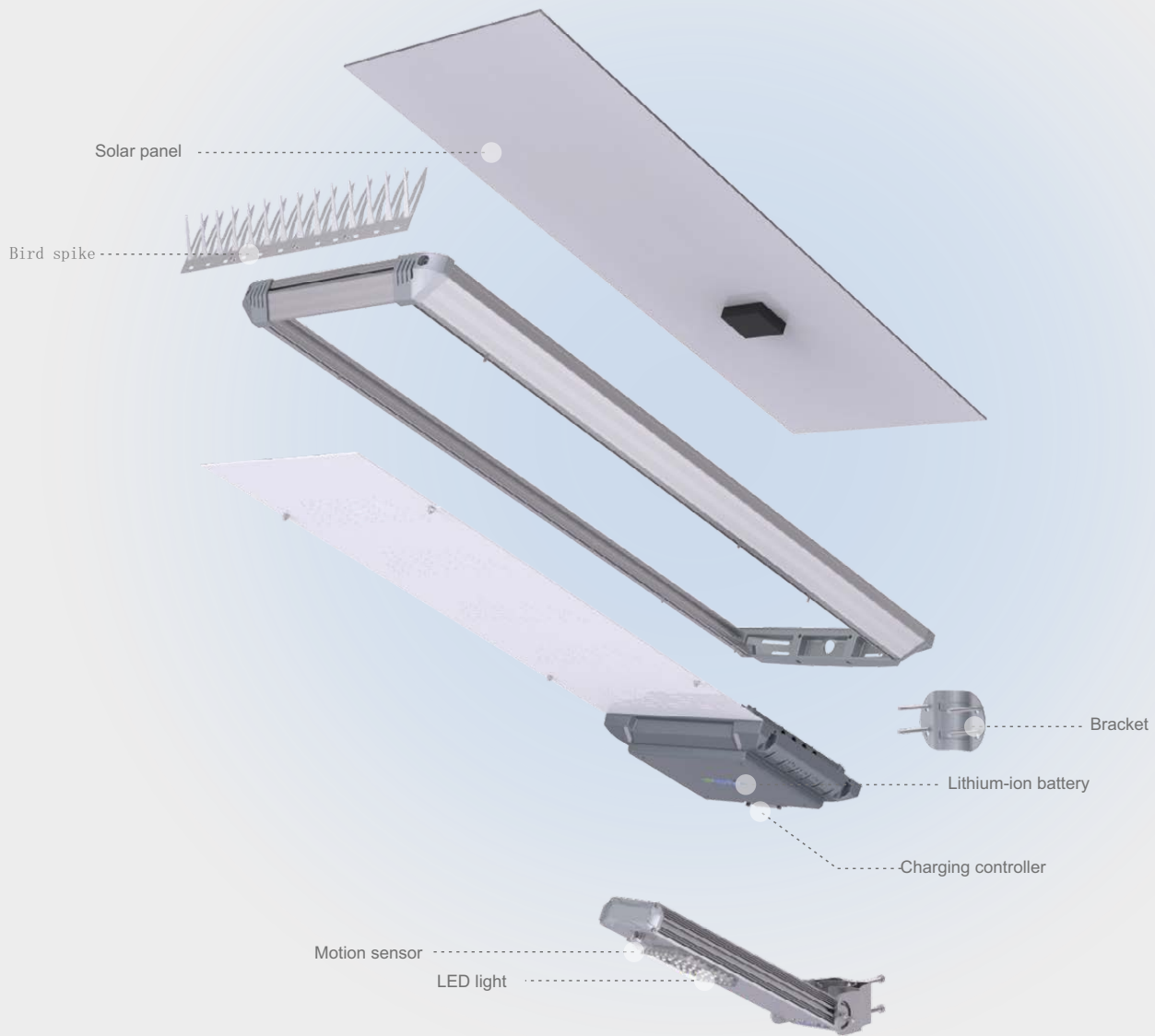

## Protected Against All Weathers

The PBOX X5 series solar street lights can withstand cold and hot weather. The modular structure of the PBOX X5 is extremely good at protecting the essential parts of the street lights. It reaches IP66 protection grade, effectively isolating humidity, dust and heat invasion, making it easy to overcome the challenges of harsh outdoor environments.

# Simple Installation, Extremely Practical

The PBOX X5 stand-alone solar street lights are very simple to use, no separate battery pack required and no complicated wiring or settings. All you need to do is to attach it to the post with some screws. That is all.

The X5 will switch on automatically at dusk and switch off automatically at dawn. When there is no one around, it will dim itself to reduce energy consumption; when any one approaches, it will increase its brightness to 100% immediately.



## 3 Types Installation



Arm lamp installation



Straight-pole installation  
0°-90° Adjustable



Wall mounted installation

# Eco-Friendly LiFePO4 Lithium-ion Battery

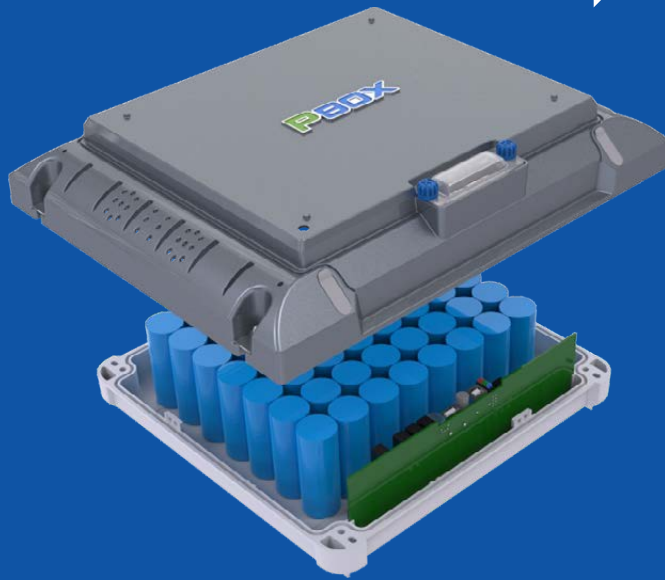

Traditional solar powered street lights use lead acid batteries that have a very short life cycle and are difficult to maintain, creating massive environmental pollution and a very low ROI. We therefore decided to use Lithium-ion batteries that have 3 times life cycle, 4 times discharge ability and are not harmful to the environment in our sealed product. Normally, LiFePO4 batteries need a proper battery management system to avoid the "barrel effect". For this, the PBOX X5 uses an exclusive patented battery management technology to enable the life span of battery to last for over 6 years, greatly improving the ROI and at the same time helping to save resources on the earth.



## Intelligent Steady State Controller

The independent researched and developed charging controller generates more power, especially during cloudy & rainy days. It simultaneously has protection for over current, over voltage and over heating. Through the USB interface on the controller, it is able to easily modify its operating mode.

# High-efficient LED with Excellent Heat Dissipation Creates a first-class light source

By choosing the top brands 5W LED chips, single lumen value up to 200lm/W (@25 °C), with the aluminum lamp base and sealed lens, with its excellent heat dissipation, it is as if the LED chip has been placed in a sealed unit. Thus it maintains high brightness levels with very little fading. The sealed lenses are made of strong UV protected PC and are aging and shock resistant; The well optimized light distribution, makes a more uniform illumination and wider lighting area.



## MONOCRYSTALLINE MODULE High efficient and Durable

19.6% photoelectric Conversion Efficiency  
Ending with 85% output in 20 years  
3.2mm tempered glass lamination for excellent  
mechanical load resistance.

## SUPER ALUMINUM FRAME makes this a tough unit

PBOX X5 uses a super aluminum frame, which is light weight, strong and corrosion resistant, making it able to resist strong wind load of up to 130MPH. Stainless steel screws are used as fasteners to protect against any harsh weather.

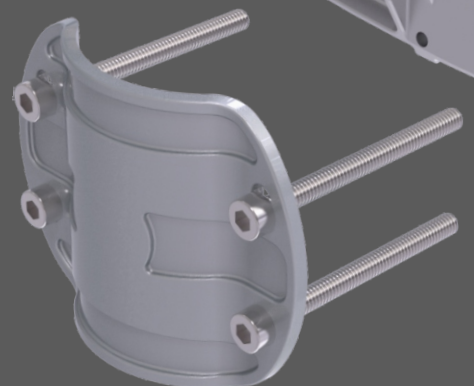

# Bat Wing Light Distribution

The new lens design improves the lighting effect and lighting uniformity, while also increasing light coverage.

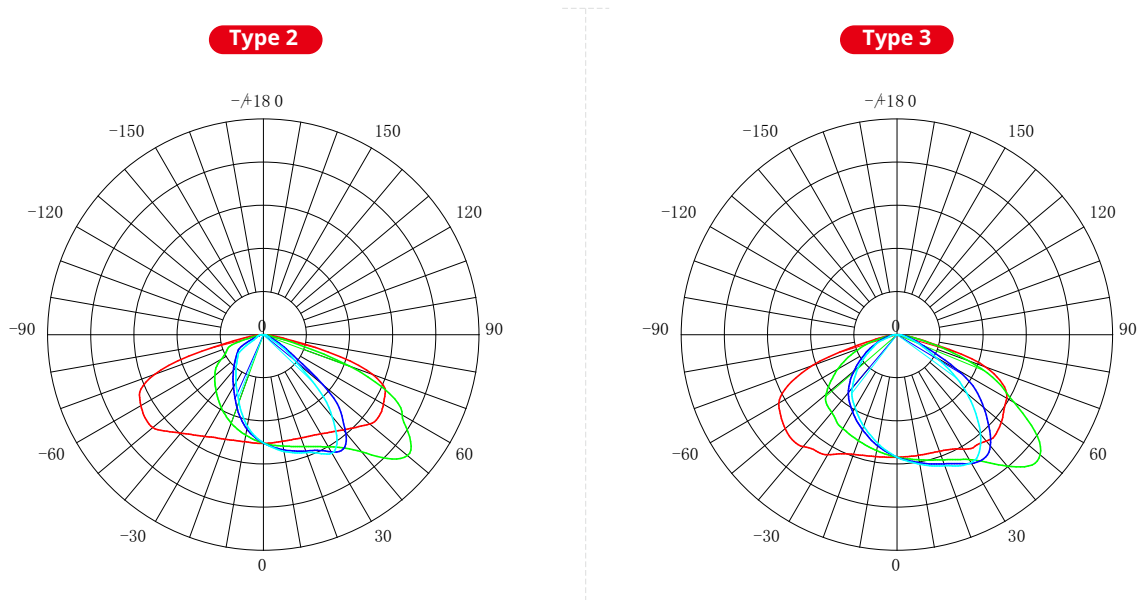

PBOX X5 comes complete with built-in motion detection system that automatically regular the light source from full bright to dim mode to increase battery autonomy.

100% Brightness when motion is detected

25% Brightness when no motion is detected

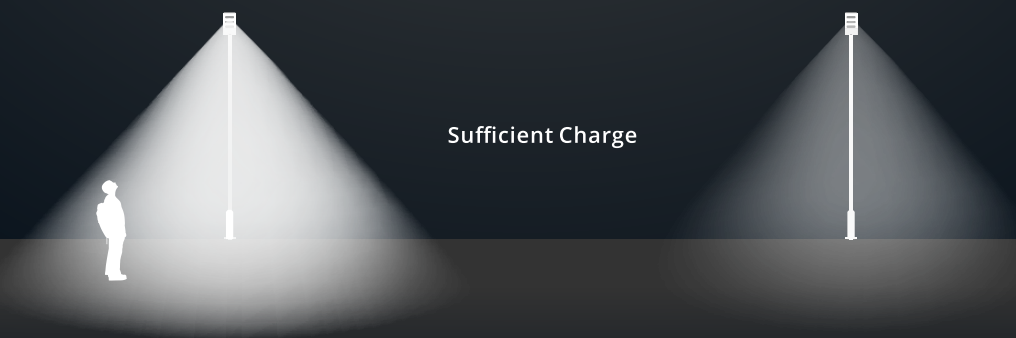

**For example:** when the battery storage capacity is sufficient, the lamp power is on standard output (100% brightness when it detects someone, 25% brightness when no one there).

## X5 Solar Street Light Specification

Model No.	X5BP-SL30	X5DQ-SL40
<b>Physical Parameters</b>		
Power of PV Module (W)	60	90
Battery Capacity (Wh)	410	512
PIR Sensor	√	√
Working Mode		
Light Photosensitivity (lx)	30	30
Net Weight of Product (kg)	11	15
Dimensions of Product (mm)	943(L)×427(W)×114(T)	1285(L)×427(W)×114(T)
<b>Packing Parameters</b>		
Dimensions of Carton (mm)	995(L)×300(W)×505(H)	1335(L)×300(W)×505(H)
Gross Weight per Carton (kg)	25	35
Qty Per Carton (pcs)	2	2
<b>Environment Requirement</b>		
Charge Temperature	0°C~54°C	0°C~54°C
Discharge Temperature	-20°C~54°C	-20°C~54°C
Storage Temperature (<3 months)	-20°C~45°C	-20°C~45°C
Storage Temperature (3~12 months)	-20°C~25°C	-20°C~25°C
<b>Mounting Recommendation</b>		
EPA (Effective Projected Area) (ft <sup>2</sup> )	2.2	3.0
APA (Actual Projected Area) (ft <sup>2</sup> )	1.83	2.5
Wind Load Rate (mph)	110	110
Top of Pole or Tenon OD (mm)	75~90	75~90

### Physical Dimensions (mm)

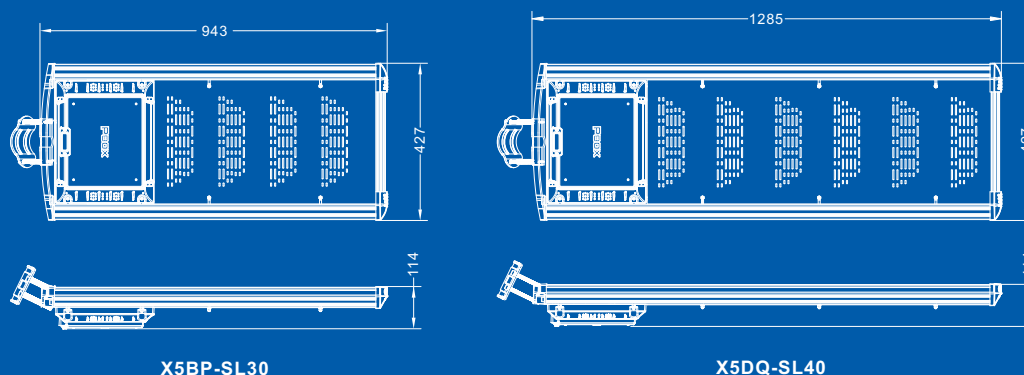

- ★ The light source contained in this luminaire shall only be replaced by the manufacturer or its agent or a qualified person. The torque setting for any bolts or screws used to secure the luminaire to the bracket is 14 N/m. Use for outdoors only.

## LED Street Light Specification

<b>Model No.</b>	X5BP-SL30(L)/X5DQ-SL40(L)/X5DQ-SL50(L)
<b>LED Module Parameters</b>	
Light Output (W)	30/40/50
Qty. of LED Chips	36
Optional Light Distribution	T2/T3
Typical Luminous Flux (lm)	5600/7300/8800
Color Temperature (K)	5000
PIR Sensor	●
Dimension of Product (mm)	519×169×150
Net Weight of Product (kg)	3
<b>Packing Parameters</b>	
Dimension of Carton (mm)	675×215×205
Gross Weight of Product (kg)	7.5
Storage Temperature	-20°C~45°C
<b>Mounting Recommendation</b>	
EPA (Effective projected area) (ft <sup>2</sup> )	0.42
APA (Actual projected area) (ft <sup>2</sup> )	0.35
Wind Load Rate (mph)	110
Top of Pole or Tenon OD (mm)	55~60
Recommended Installation Height (m)	5~8
Recommended Installation Distance (m)	15~35

### Physical Dimensions (mm)

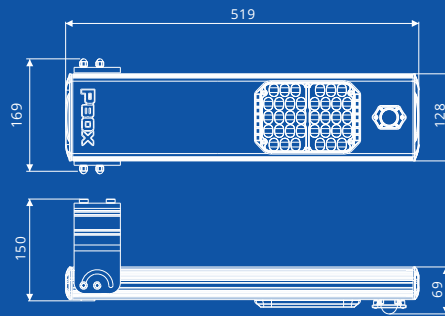

- \* The light source contained in this luminaire shall only be replaced by the manufacturer, its service agent or a qualified person.  
The torque setting for any bolts or screws used to secure the luminaire to the bracket is 14 N/m.  
Use for outdoors only.